

SECTION VIEW

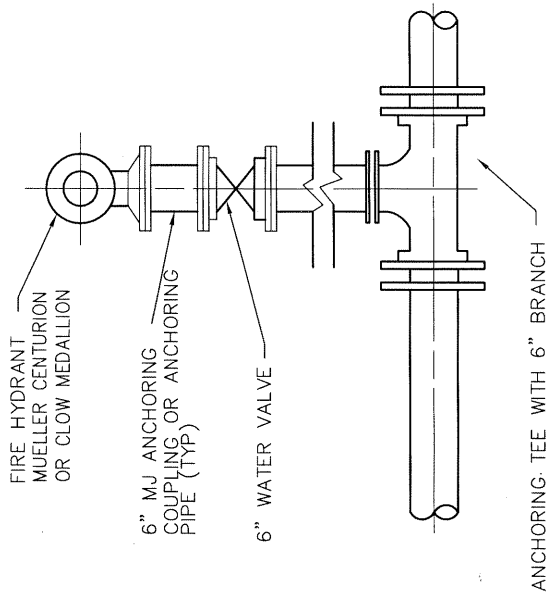

BASIC TEE DETAIL PLAN

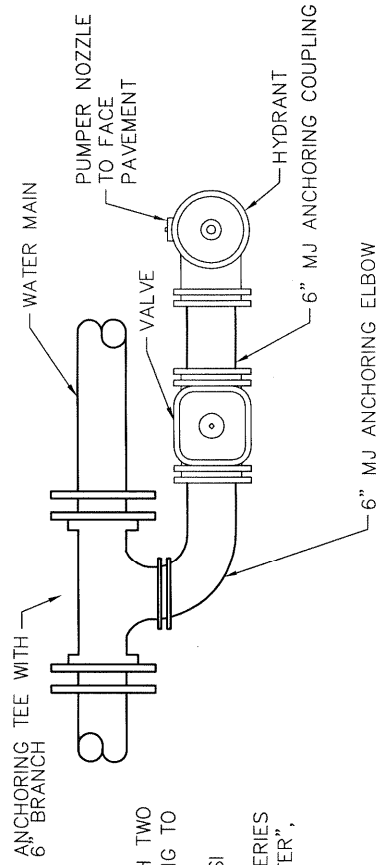

**SPECIAL MECHANICAL JOINT
HYDRANT TEE DETAIL PLAN**

NOTES

- A. FIRE HYDRANTS SHALL BE MUELLER CENTURION OR CLOW MEDALLION, A-423, MECHANICAL JOINT, WITH TWO (2) 2 1/2" HOSE NOZZLES, ONE (1) 4 1/2" PUMPER NOZZLE, NATIONAL STANDARDS THREADS CONFORMING TO AWWA CCW TO OPEN, BREAK FLANGES 3" ABOVE GRADE.
- B. GATE VALVES SHALL BE AWWA C-509, RESILIENT WEDGE, NONRISING STEM, MECHANICAL JOINT, 150 PSI WORKING PRESSURE, CCW TO OPEN WITH ARROW INDICATING OPEN DIRECTION, MUELLER OR EQUIVALENT.
- C. VALVE BOXES - 3-PIECE CAST IRON EAST JORDAN SERIES 8550 TOP SECTION, EAST JORDAN 8560 SERIES MID SECTION, EAST JORDAN #6 BASE, ADJUSTABLE SCREW TYPE WITH EAST JORDAN COVER MARKED "WATER", DOMESTIC MADE ONLY.
- D. ALL FITTINGS TO BE RESTRAINED.
- E. ALL FITTINGS TO BE AWWA C-153 DUCTILE IRON, COMPACT.
- F. ALL VALVES AND HYDRANTS SHALL OPEN LEFT BY TURNING IN A COUNTERCLOCKWISE DIRECTION.
- G. CONTRACTOR TO FACE HYDRANT.
- H. WATER MATERIAL SHALL BE DUCTILE IRON PIPE CLASS 52, AWWA C-151, SLIP-ON JOINTS WITH RUBBER GASKETS, OR PVC-150, DR-18, AWWA C-900 WITH RESTRAINED FITTINGS.
- I. THE LAYING OF PIPE ON EXISTING DIRT WITH THE BELLS CUT OUT, SHALL NOT BE PERMITTED.
- J. THE OPEN ENDS OF ALL PIPES AND SPECIAL CASTINGS SHALL BE PLUGGED OR OTHERWISE CLOSED WITH A WATERTIGHT PLUG TO THE APPROVAL OF THE VILLAGE BEFORE LEAVING THE WORK FOR THE NIGHT.
- K. ALL DUCTILE FITTINGS, PIPE AND BARREL OF HYDRANT TO BE WRAPPED WITH 8ml POLYWRAP AS MANUFACTURED BY TRUMBULL INDUSTRIES.

VILLAGE OF
ADA

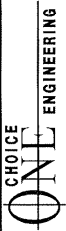

REVISIONS:
10-14-2005
6-2-2008

DATE
APPROVED:
MAY 1997
PAGE No.
800-1

FIRE HYDRANT